

Ce camion est uniquement loué avec ouvrier-machiniste !

Performances

Hauteur de travail max.	54 m
Hauteur de plancher max.	52 m
Charge utile max.	600 kg
Déport max. (charge 100 kg)	40 m
Déport max. (charge 600 kg)	32 m
Rotation de la tourelle (en continue)	500°
Rotation du panier	90 + 90°
Angle du Jib	180°

Dimensions

Dimensions du panier (larg. x long. x haut.)	0.97 x 2.42 x 1.1 m
Largeur de la machine	2.55 m
Longueur de la machine	11.96 m
Hauteur de la machine	3.93 m
Extension du panier (larg. x long.)	0.97 x 3.82 m
Passage des portes (larg. x long.)	2.55 x 3.93 m

Poids

Poids de la machine	26'000 kg
---------------------	------------------

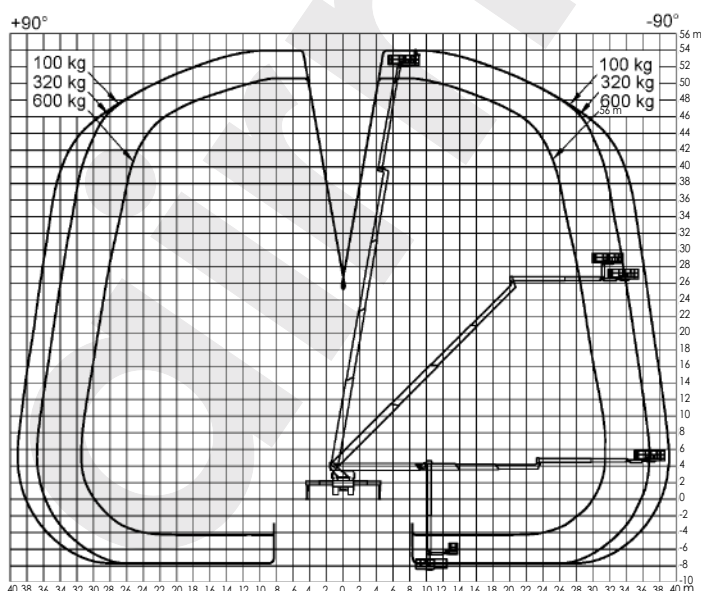

31.12.2020



-90°

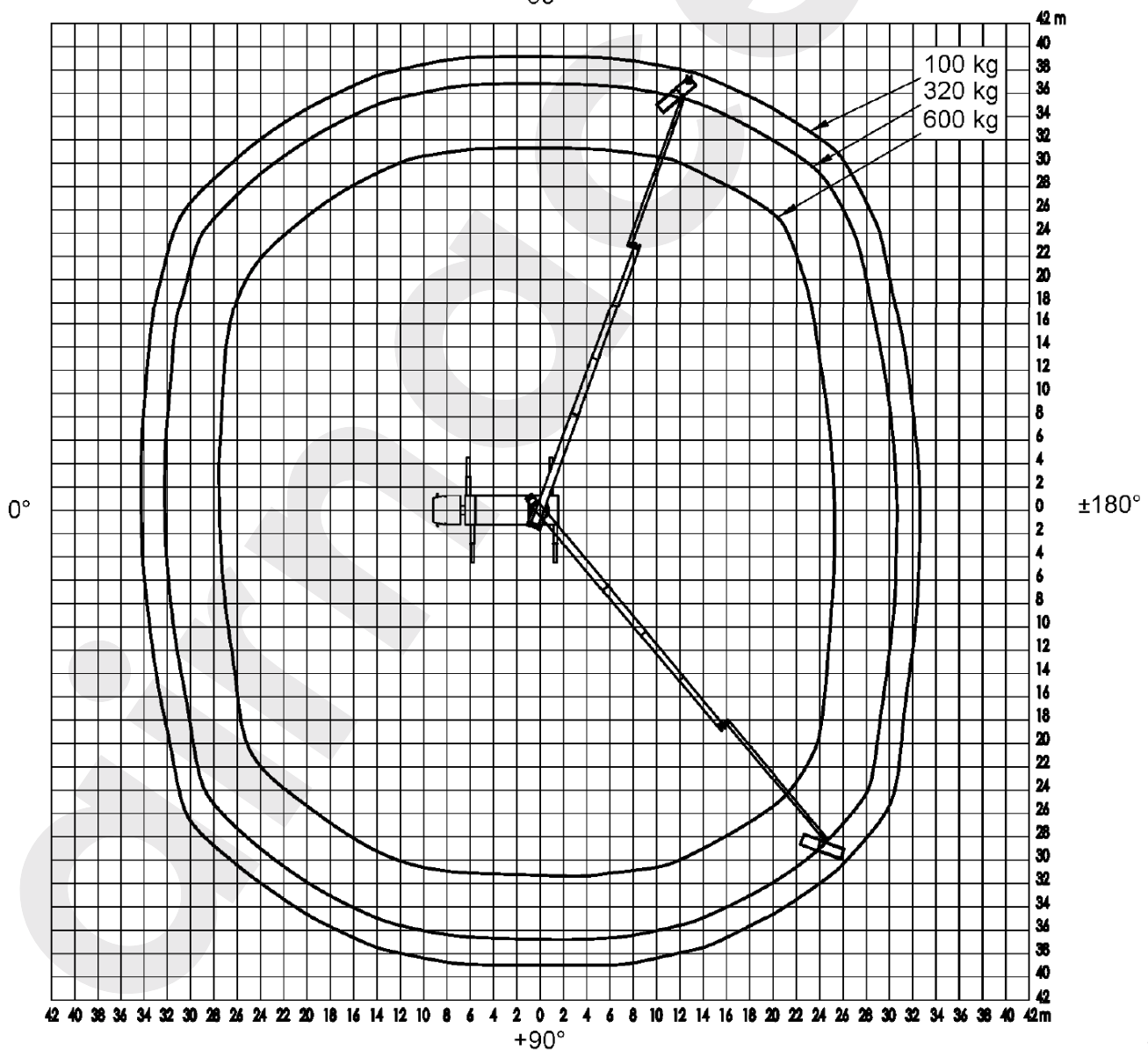

20.02.2020

